

**Introduction of the NEW High Performance Double Hung Tilt and Slide Window Range.
Quality as Standard, Not an Option.**



Manufactured from Quality knot free Laminated / Engineered Baltic Pine.

Windows are supplied fully finished in White as standard RAL 9010, with options for any RAL colour.

Also options for dual colour frames, or painted exterior lacquer interior, or stain / lacquer finish interior and exterior.

Available in solid Oak.

Units are Glazed as standard with Pilkington Low E 20mm Double Glazing with 90% Argon Gas Fill. U Value 1.5.

Caldwell mechanism's. Reddiseals furniture fitted as standard, Polished Chrome key locking handles. Also available in Polished Brass and Satin Chrome.

Frame 156mm x 70mm.

Titon Trimvents as standard.

Units come with extensive Warranties, 10 years sealed units and hardware, 5 years paint finish, 10 years on timbers.

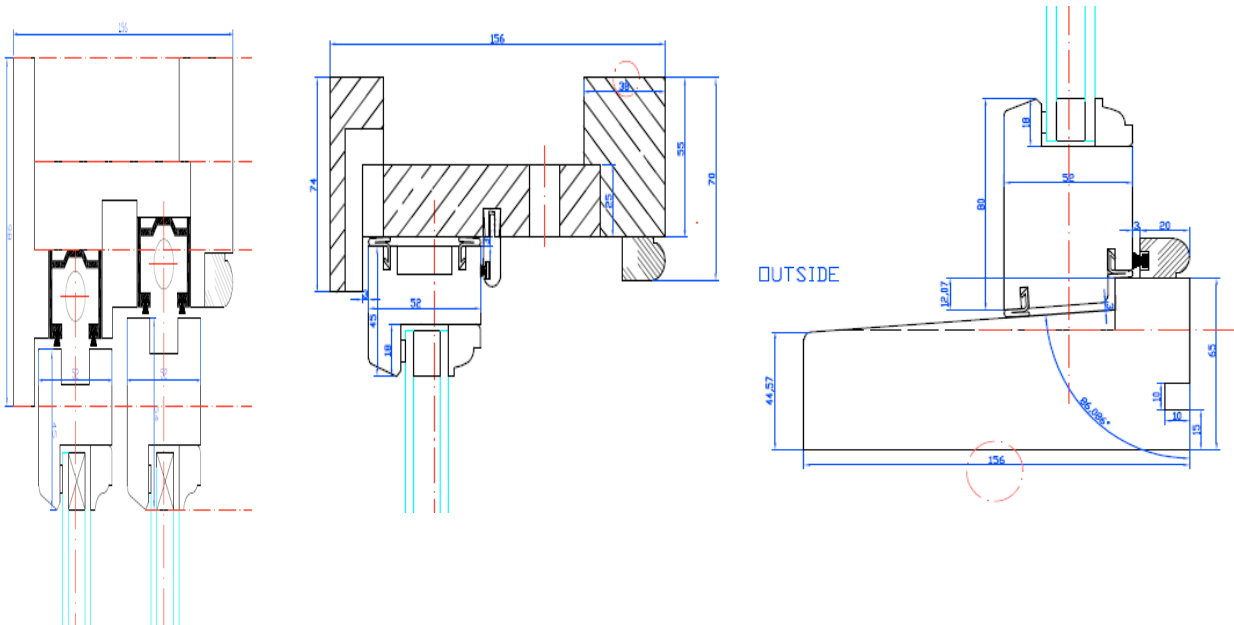

Description

Double Hung type unit with Tilt and slide facility. Fully Finished in White with Sikkens paints.

Frame & Sash Materials

Engineered Baltic Pine (knot free).

Preservation

All timber components are pressure impregnated with Sikkens WV881 for Pine and WP520 for Oak to prevent against insect and fungal attack.

Factory Finish

Windows are supplied fully finished in White RAL 9010 as standard, with options for any RAL colour.

Also options for dual colour frames, or painted exterior lacquer interior, or stain / lacquer finish interior and exterior.

Furniture

Reddiseals furniture fitted as standard, Polished Chrome key locking handles. Also available in Polished Brass and Satin Chrome.

Weatherseal

Schlegel weather strips.

Glazing

Windows are factory glazed with Pilkington Low E glazing with 90% Argon Gas fill, 20mm (4-12-4) tested to EN1279

U Value 1.5.

Ventilation

Titon Trimvents as standard.

Mechanisms

Caldwell mechanism's.

Grilles

FDL, available 18mm, 24mm, and 32mm profile.

Sizing

Max width 1500mm

Max height of window 2800mm

Min width of window 400mm

Min height of window 830mm



It is not possible to produce a unit 1500mm x 2800mm please ask for more information when quoting large units.

Guarantees

10 years on sealed units and hardware, 5 years on paint finish against fading, 10 years on timber portions.

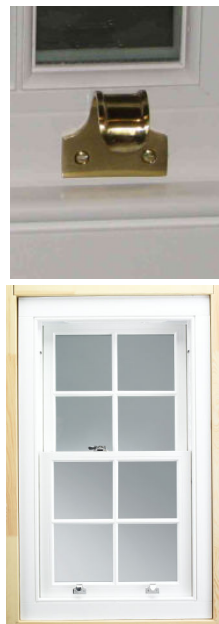

Black Millwork Co Inc

Andersen House
Dallow Street
Burton on Trent
Staffordshire
DE14 2PQ

Phone: 01283 511122

Fax: 01283 510863

E-mail: info@blackmillwork.co.uk

Web: www.blackmillwork.co.uk

Black
MILLWORK CO., INC.